



FLEX+ TOPPLE WITH GROUND GUARD



Find Me
online:
→



PERFORMANCE BY DESIGN

FLEX+ is a high-performance system, engineered with purpose – built to absorb, adapt, and deliver protection where it matters most.

RAILS OPTIMIZED FOR PERFORMANCE

Elliptical rails are designed to flex and return to shape – delivering the ideal balance of coverage and energy absorption.

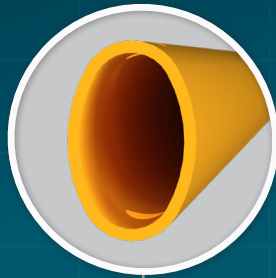

PRECISION-ENGINEERED CONNECTIONS

Inside every post: FlexLink impact absorption and FastFit modular inserts – built to absorb impacts and hold strong.

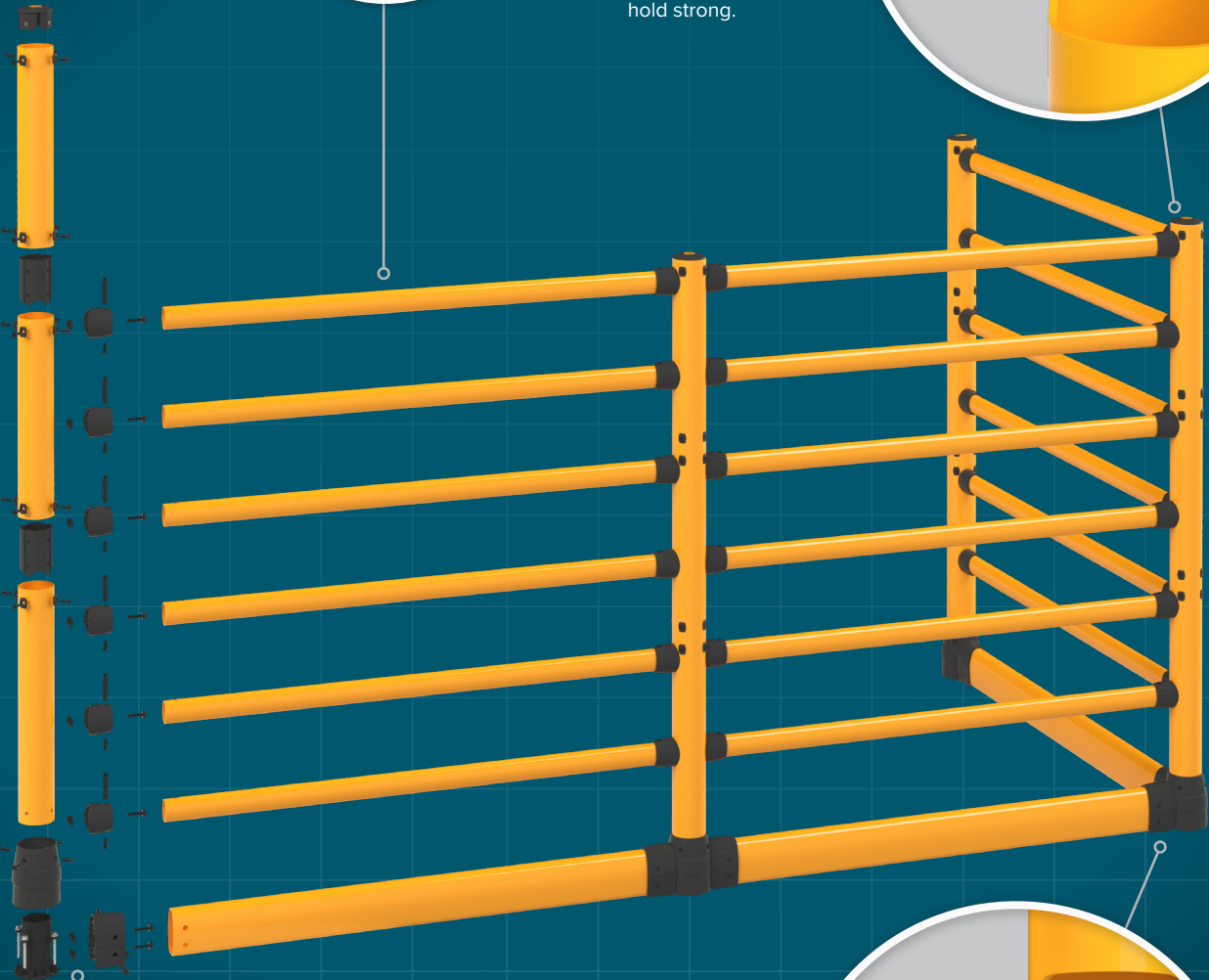
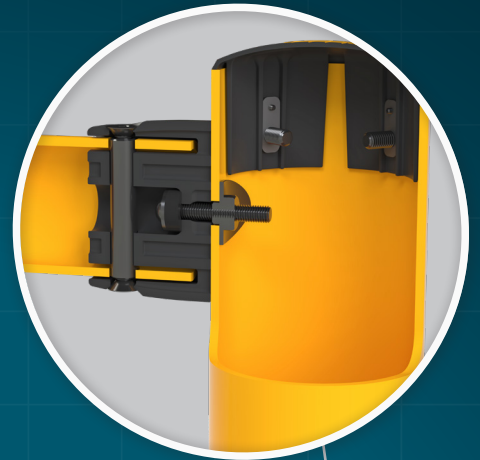

SMART CONNECTIONS, BUILT TO FLEX

FlexLink Connector Technology absorbs impacts and distributes force through the system.

POLYCORE BASE: GROUNDED IN STRENGTH

The PolyCore Base anchors securely to the ground – combining internal strength with a durable, impact-resistant exterior.



IMPACT TEST RESULTS

Documented performance from standardized testing.

MIDSPAN ENERGY ABSORPTION AT 90°
7,380 J

MIDSPAN DYNAMIC PENETRATION
11.4" | 290 mm

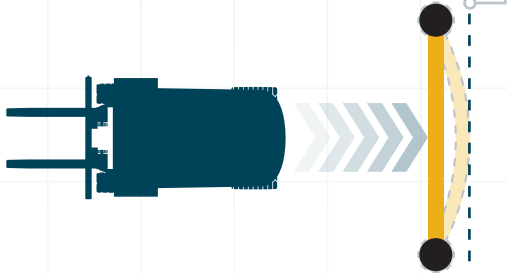

UPRIGHT ENERGY ABSORPTION AT 90°
7,070 J

UPRIGHT DYNAMIC PENETRATION
24.5" | 599 mm

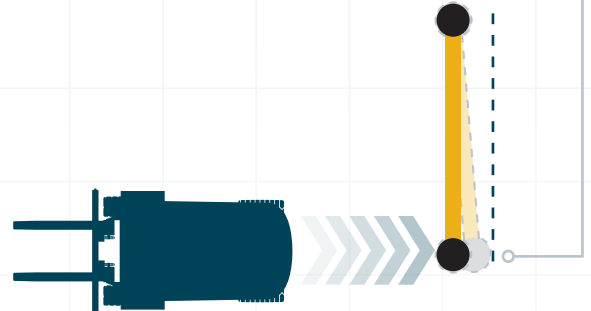

ENERGY EQUIVALENCE BY EQUIPMENT TYPE

$$\frac{1}{2} \text{ MASS } \times \text{ VELOCITY}^2 = \text{ENERGY}$$

Values shown reflect the kinetic energy of real equipment impacts.



ELECTRIC PALLET JACK

MASS & VELOCITY	
IMPERIAL	3,000 lb 7.37 mph
METRIC	1,361 kg 11.9 kmh



WALKIE RIDER

MASS & VELOCITY	
IMPERIAL	6,000 lb 5.21 mph
METRIC	2,722 kg 8.38 kmh



FORKLIFT



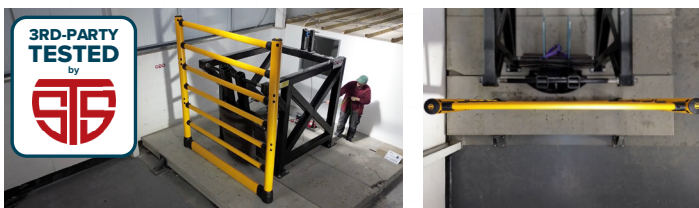

MASS & VELOCITY	
IMPERIAL	10,000 lb 4.04 mph
METRIC	4,536 kg 6.49 kmh

3RD PARTY TESTED



CLICK OR SCAN TO SEE THE THIRD-PARTY TESTING FOOTAGE

MATERIAL PROPERTIES

	Working Temperatures	32°F-130°F (0°C-54°C)
	Flammability	Does Not Easily Ignite
	Toxicity	Not Hazardous
	Recyclability	Fully Recyclable

PRODUCT SPECIFICATIONS & PURCHASING YOUR PRODUCT

FLEX+ TOPPLE WITH GROUND GUARD

Hardware included.

