

# SLT Aluminum Corner Guards™

SLT Aluminum Corner Guards™ provide a modern and attractive appearance for corner protection. Easily installed, these guards are made of .060, .080, or .125 Aluminum with a brushed #4 Satin finish. These corner guards are used for a wide variety of industrial, commercial and residential applications to withstand damage to walls and for its aesthetic appeal. They are ideal for medium to high impact areas. These Corner Guards provide maximum protection in restaurants, hospitals, clean rooms, office spaces, common areas, storage spaces, parking garages, loading docks, food processing areas and countless other applications.

SLT Aluminum Corner Guards™ can be mounted vertically or horizontally along the corners of walls or beams to prevent damage. Corner Guards are made out of a variety of materials providing our customers a flexibility in looks.

**Backed by a limited lifetime warranty.  
All corner guards are Class VA fire rated and  
meet national building code standards.**

- ▶ Easy Installation  
(Quick installation with optional screws or customer supplied adhesive such as "LiquidNails")
- ▶ Hygienic
- ▶ Low Maintenance
- ▶ Tough, durable and long-lasting
- ▶ Beautiful
- ▶ Made from top quality materials



SLT means "Short Lead Time."  
Custom Heights, Widths and Angles in  
Days NOT Months.

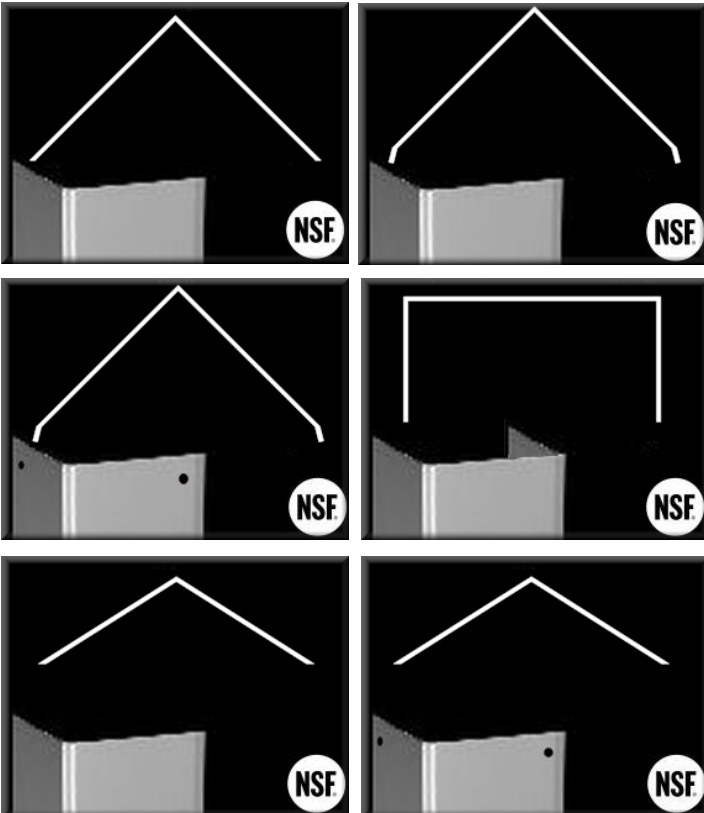

 **TheCornerGuardStore.com**

**800-516-4036**

**www.TheCornerGuardStore.com**

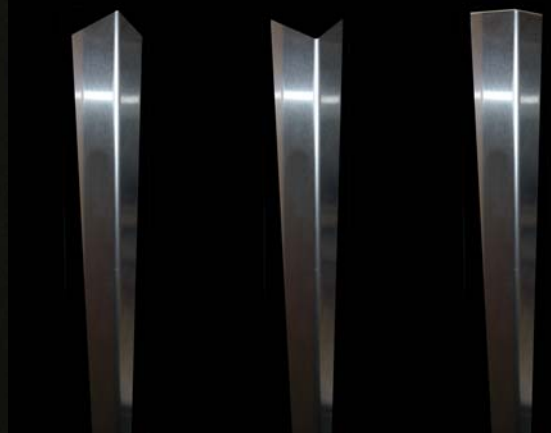
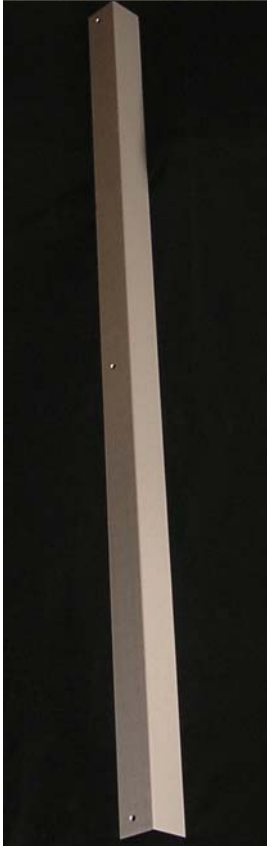
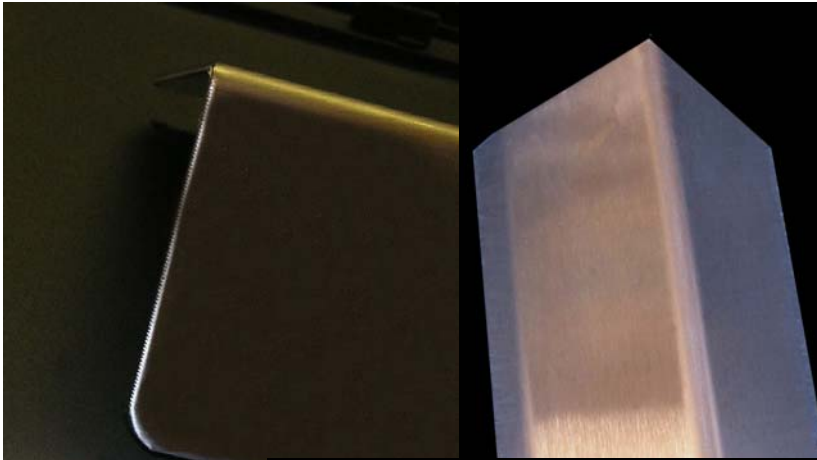

# SLT Corner Guards™

## Aluminum Corner Guards

### Adhesive Application (Standard)

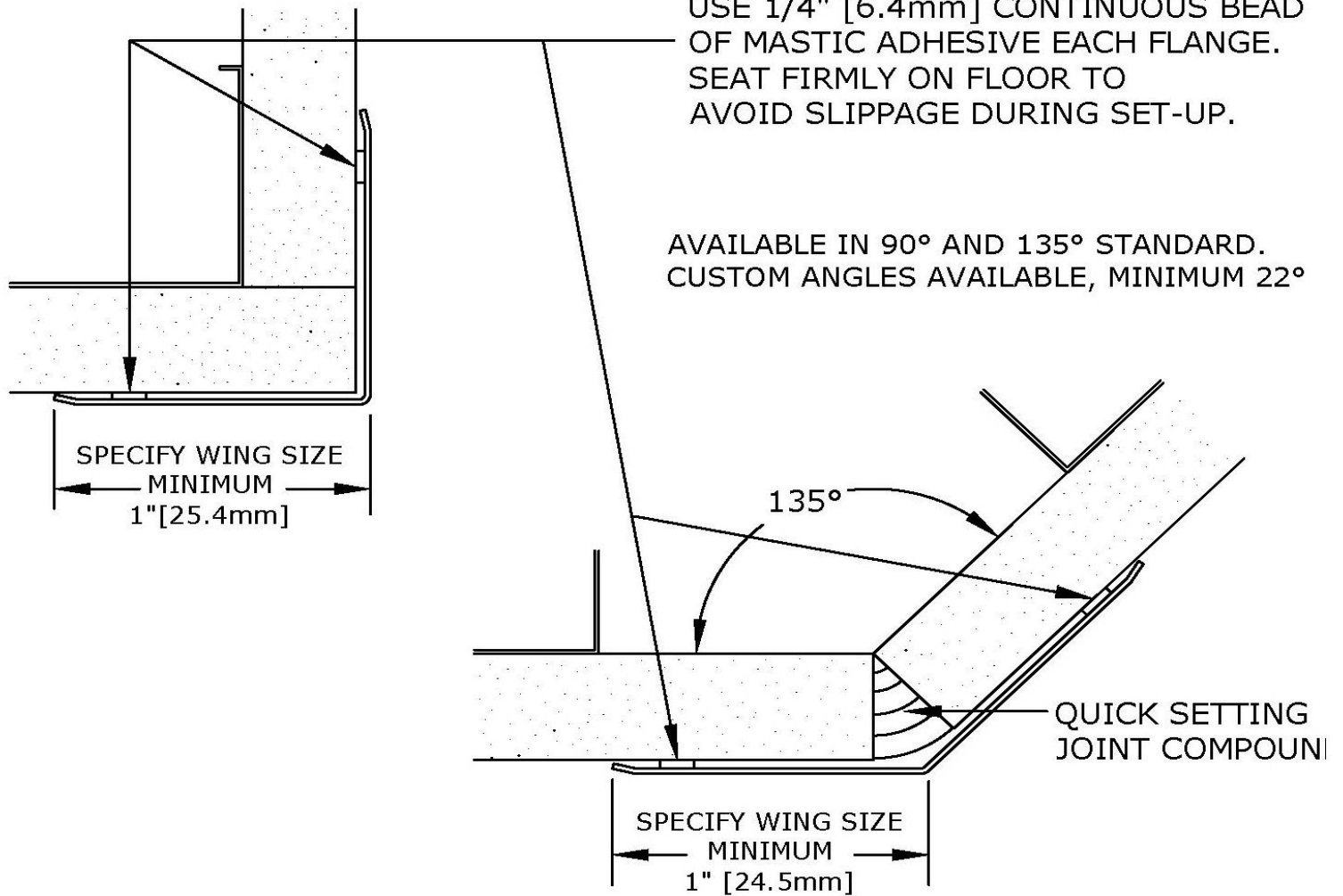

**IMPORTANT:** USER SHALL VERIFY CONFORMANCE OF ALL CONSTRUCTIONS SHOW WITH LOCAL CODES.

#### GENERAL SPECIFICATION

16 GA. ALUMINUM, TYPE 5252, BRUSHED STAIN NO. 4 FINISH, WITH ROUNDED EDGES AND PROTECTIVE COATING

CONTINUOUS LENGTH AVAILABLE: 10' (3.05M) MAXIMUM

OPTIONS AVAILABLE:: HOLES, WINGS

FINISHES AVAILABLE:: BRUSHED NO. 4, 2B, CUSTOM HAND FINISHES

OPTIONS AVAILABLE:: 1/4" THROUGH 22GA. MOST COMMON 16GA



800-516-4036

[www.TheCornerGuardStore.com](http://www.TheCornerGuardStore.com)

# SLT Corner Guards™

## Aluminum Corner Guards

### Fastener Application (Optional)

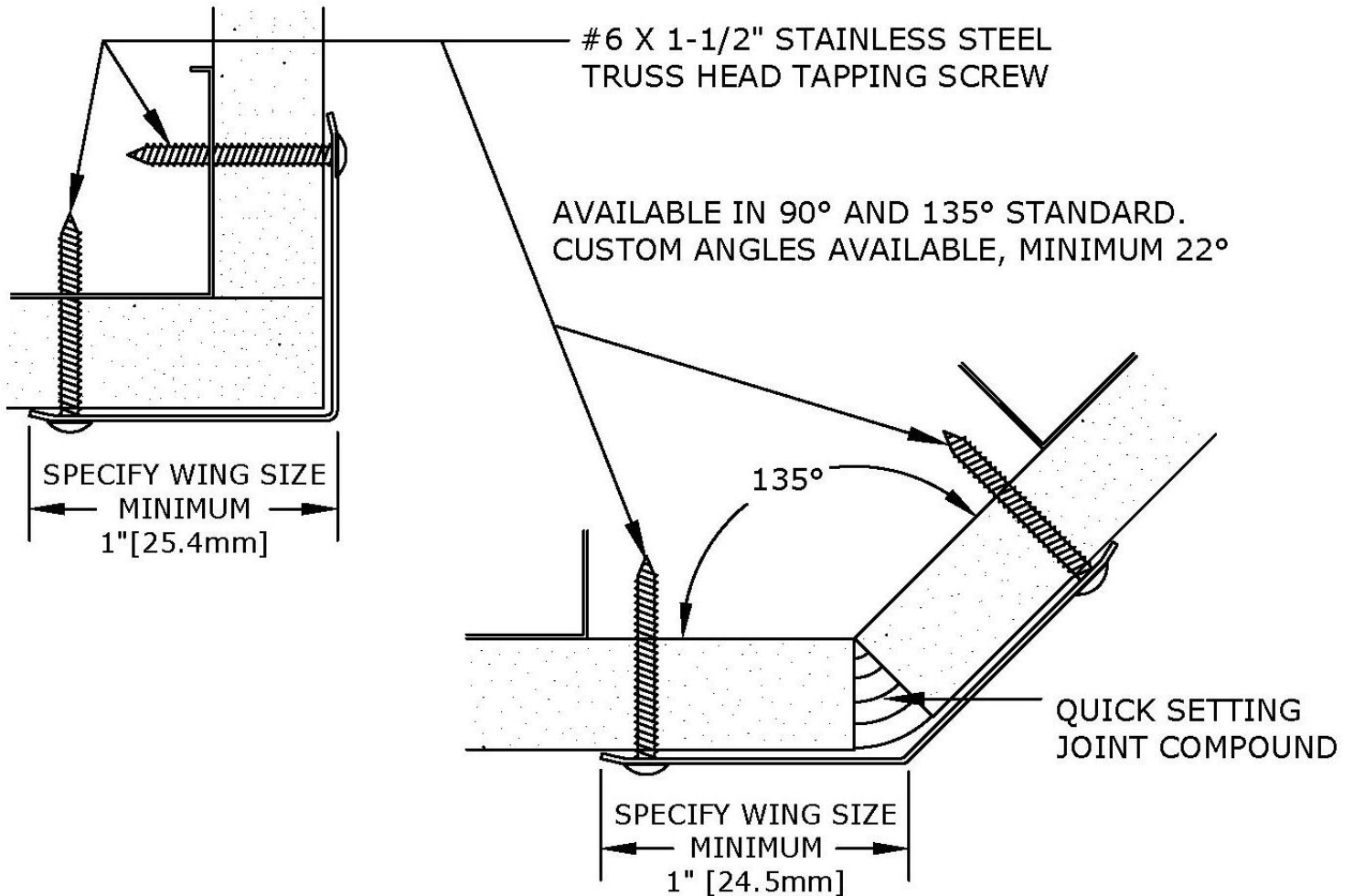

**IMPORTANT:** USER SHALL VERIFY CONFORMANCE OF ALL CONSTRUCTIONS SHOW WITH LOCAL CODES.

#### GENERAL SPECIFICATION

16 GA. ALUMINUM, TYPE 5252, BRUSHED STAIN NO. 4 FINISH, WITH ROUNDED EDGES AND PROTECTIVE COATING

CONTINUOUS LENGTH AVAILABLE: 10' (3.05M) MAXIMUM

OPTIONS AVAILABLE:: HOLES, WINGS

FINISHES AVAILABLE:: BRUSHED NO. 4, 2B, CUSTOM HAND FINISHES

OPTIONS AVAILABLE:: 1/4" THROUGH 22GA. MOST COMMON 16GA



800-516-4036

[www.TheCornerGuardStore.com](http://www.TheCornerGuardStore.com)

# SLT Corner Guards™

## Aluminum Corner Guards and EndCaps

### Picture and Profiles

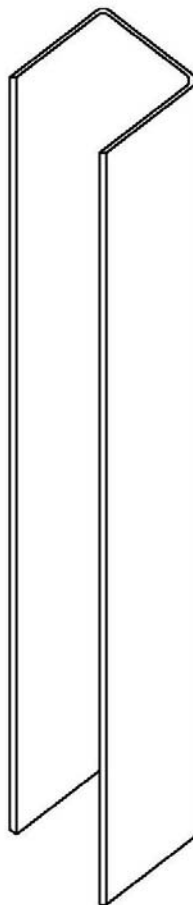

# SLT Corner Guards™

## Aluminum Corner Guards and EndCaps

### Product Guide Specification

#### SECTION 10260 CORNER GUARDS

##### PART 1 GENERAL

###### 1.01 SECTION INCLUDES

Aluminum Corner Guards.

###### 1.02 SUBMITTALS

- A. Submit in accordance with Section 01300—Submittals.
- B. Product Data: Submit manufacturer's product data.
- C. Samples: Submit for approval 12" (5252.8mm) long sample of each color specified.
- D. Test Reports: Submit manufacturer's test reports and certification indicating compliance with applicable building code requirements.

###### 1.03 QUALITY ASSURANCE

Comply with specified project requirements regarding fit and finish.

###### 1.04 DELIVERY, STORAGE, AND HANDLING

- A. Delivery: Deliver materials to site in manufacturer's original, unopened containers and packaging with labels clearly identifying product name and manufacturer.
- B. Storage: Store materials in a clean, dry location protected against damage of any kind.

##### PART 2 PRODUCTS

###### 2.01 MANUFACTURER

TheCornerGuardStore and Seelye Craftsmen, Inc.

###### 2.02 CORNER GUARDS

SLT Aluminum Corner Guard™ Series 16-gauge Aluminum Corner Guard adhered or screwed to substrate corner. Exposed surfaces shall be free of discoloration or other imperfections.

###### 1. Dimensions

- a. Leg length: 1" (25.4mm)—CG-SS4-xx1; 1-1/2" (38.1mm)—CG-SS4xx1.5; 2" (50.8mm)—CG-SS4-xx2; 3" (76.2mm)—CG-SS4-xx-3; and 3-1/2" (88.9mm)—CG-SS4-xx35.
- b. Angle: 90° (Custom Angle Available).

###### 2. Material: Aluminum, type 5252.

###### 3. Finish: #4 Satin.

##### PART 3 EXECUTION

###### 3.01 EXAMINATION

Verify by examination that wall surfaces are acceptable to receive the specified guard systems. Notify the Architect in writing if wall surfaces are not acceptable. Do not begin installation until unacceptable conditions have been corrected.

###### 3.02 INSTALLATION

- A. Install corner guards to wall securely using mastic construction adhesive or appropriate screws, as specified.
- B. Install corner guards accurately in location, alignment, and elevation.



800-516-4036

[www.TheCornerGuardStore.com](http://www.TheCornerGuardStore.com)

# SLT Corner Guards™

## Aluminum Corner Guards and EndCaps

### Installation Instructions

Recommended Installation Equipment: Drill/Screwgun and Screw Bit, or Mastic Construction Adhesive.

1. SLT Aluminum Corner Guards™ are supplied in specified lengths and with attachment screw holes as specified. A peel-off plastic coating protects the finished face of the corner guards.
2. Check material for compliance with Project Specifications and for any damage that may have occurred during shipment and/or handling at job site.
3. In accordance with facility architectural drawings and specifications, locate and install SLT Corner Guards™ per the appropriate location drawing(s).
4. The wall surface where the corner guards are to be applied must be dry and free of contaminants.

#### Cement-On Installation:

- 5a. Apply construction adhesive in a zig-zag pattern over the back surface of each wing of the corner guard.
- 5b. Position corner guard on the wall appropriately and apply pressure along entire height until a tight and secure fit is achieved.
- 5c. Remove the protective plastic coating from the face of the corner guard.

#### Screw-On Installation:

- 6a. Attach corner guard to wall with specified attachment hardware (supplied by others).
  - 6b. Remove the protective plastic coating from the face of the corner guard.
7. Clean with dry or slightly damp cloth as necessary.
  8. If you have any questions during installation, please contact your local SLT Corner Guards™ representative.



800-516-4036

[www.TheCornerGuardStore.com](http://www.TheCornerGuardStore.com)



*Thank you for your interest in TheCornerGuardStore!*

We hope the enclosed sample will answer many of the questions you may have about our products. If you still have questions after reviewing the sample please give us a call at 1-800-516-4036.

- Winged edge; straight cut, deburred and "kinked" approximately 8-10 degrees. Allows cornerguard to grip the wall better.

- All holes are countersunk so screws sit flush.
- All orders with holes are shipped with screws. (Included in the price.)
- Standard hole uses a #8 Screw, 1.25" long. If needed smaller and larger screws will be used, given the size of the cornerguard.

- Sample is fabricated using 16 gauge Aluminum. Other metals offered by TCGS include: Aluminum, Brass & Mild Steel. For a complete list please visit our website.

- Standard degree bend is 90 degree. Custom bends available upon request.

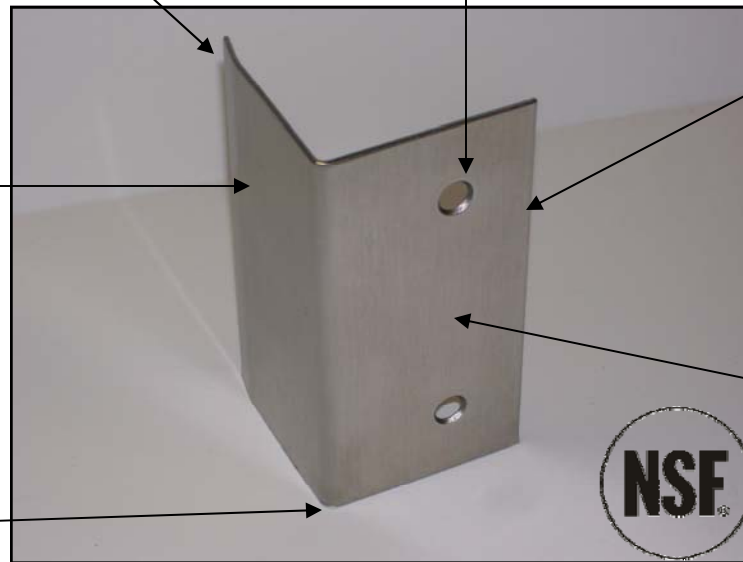

- Basic edge; straight cut and deburred. -This is our Standard edge.

- Sample is fabricated with a #4 / Brushed finish. Other finishes available include; 2B or Matte, Swirled, Painted, Anodized (for aluminum) or plated. For a complete list please visit our website.



**Remember.....We do Kick Plates, Custom Orders & More!!!**

Please visit our Website: [www.TheCornerGuardStore.com](http://www.TheCornerGuardStore.com)

or Call

**1-800-516-4036**

for more information.